

PRODUCT NAME:

PRE-RINSE SPRING STYLE WALL MOUNT

Item: #PRW08-1F

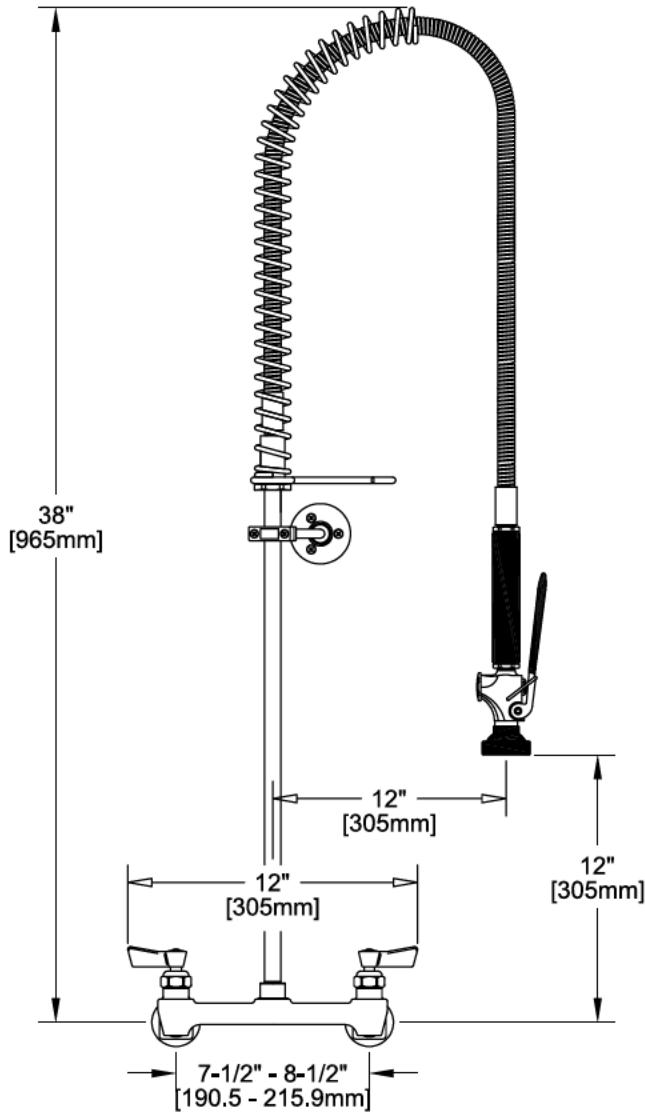

ROUGH-IN:

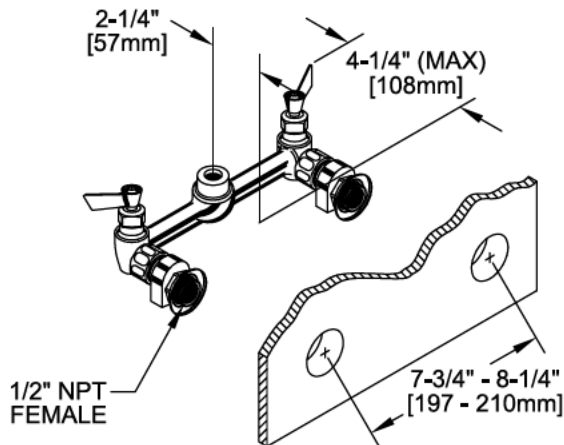

FEATURES

CONTROL VALVE

- * ECCENTRICS ADJUST FROM 7-3/4" TO 8-1/4"
- * INTERNAL SPRING LOADED CHECK VALVES
- * SWIVELLING SEAT DISKS
- * HOT SIDE STEM - RIGHT HAND
- * COLD SIDE STEM - LEFT HAND
- * STAINLESS STEEL SEATS
- * STAINLESS STEEL SEAT SCREWS
- * STAINLESS STEEL HANDLE SCREWS

HOSE

- * 36" LENGTH
- * STAINLESS STEEL END FITTINGS
- * STAINLESS STEEL EXTERNAL JACKET
- * 3 PLY FIBER REINFORCED INTERNAL RUBBER HOSE
- * REPAIRABLE IN FIELD WITH SIMPLE TOOLS

ULTRA SPRAY VALVE

- * LOWEST ENERGY USER - 1.15 GPM @ 60 PSI
- * CLEANS FASTER - TEST PROVEN
- * ENGINEERED TO LAST - NO 'O' RINGS TO LEAK
- * INTERCHANGEABLE - FITS ALL BRANDS

WALL BRACKET

- * ADJUSTS FROM 2" TO 12"

SYSTEM LIMITS

- * TEMP: 40°F MIN. TO 140°F MAX.
- * PRESSURE: 200 PSI MAX. STATIC

SHIPPING WEIGHT

- * 12.0 LBS

Distributed by :

E.D.A. International Corp. / MBH International Sales, Inc.
4907 SW 75th Ave.

Miami, FL 33155 USA

Phone: (305) 669-1894 ; Fax: (305) 669-1797

e-mail : sales@edainternational.com / sales@mbhny.com

EPAct 2005 Compliant



ANSI/A112.18.1M