

Bestsellers



Export Representatives:

E.D.A. International Corp. /MBH International Sales, Inc
4907 SW 75 Ave.
Miami, FL 33155 USA
Tel.: (305) 669-1894
Fax: (305) 669-1797
e-mail : sales@edainternational.com ; sales@mbhny.com



MAXIMIZER

Pizza Ovens

MODEL CW100P

General Features:

- **Quality Construction** for long life
- **Stainless Steel Front Standard**
- **Pizza Deck Standard**
Large 52"x36"x9" compartment
1½" pizza stone
- **Large Capacity**
Twenty 9" (22.9cm) pizzas,
Twelve 12" (30.5cm) pizzas,
or Six 16" (43.2cm) pizzas
- **Energy Efficient**
New energy-saving
"Power-Pak" burner system
coupled with our unique baffle
system for even heat and
better baking
- **Full Range Thermostat**
300°F - 650°F (149°C - 343°C)
- **Space saver**
Only 60" wide
- **Stackable**
Double cooking capacity
- **Easily Serviceable**
All controls can be replaced
from the front of the unit
- **Power**
Gas - LP or NAT
- **Specific features**
of the CW100P listed back

Warranty:

- One year parts



**GAS
FIRED**

Hearth
Baffle
Burner

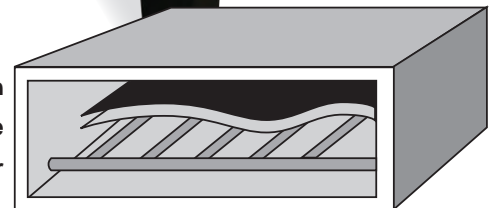

"Power-Pak" 5-Cell Burner System

MORE FOR LESS

More Cooking Space per Floor Space
More Cooking Capacity per Sales Dollar
More Performance per Gas Dollar



Commercial and Industrial Ovens

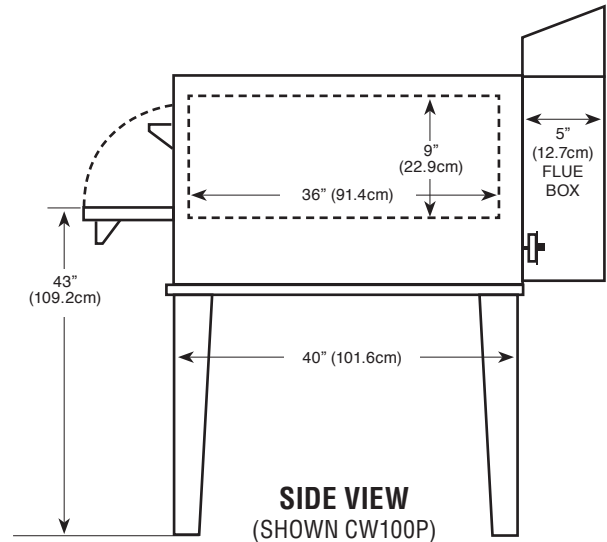
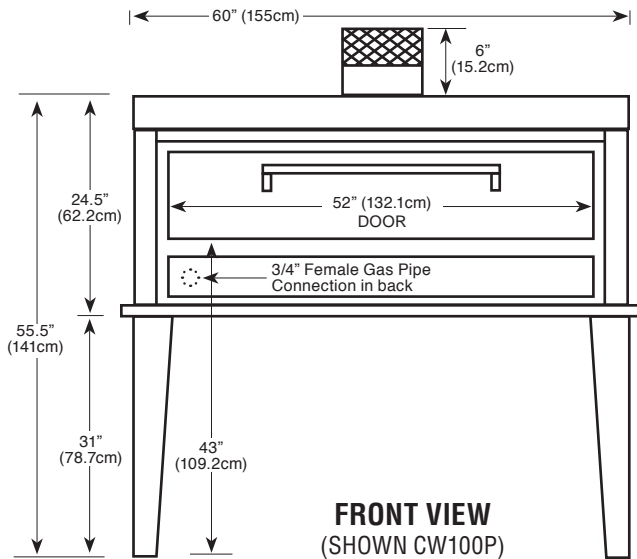
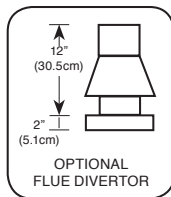

| | |
|------------------------------------|--|
| Floor space | .60”(155cm) wide x 46”(116.9cm) deep* x 55.5”(141cm) high |
| Shelf size | .52”(132.2cm) wide x 36”(91.5.3cm) deep x 9”(22.9cm) high |
| Shipping weight | 725 lbs(328.8kg) |
| Capacity | Ten 9”(22.9cm), twelve 12” (30.5cm) or six 16” (43.2cm) pizzas |
| Gas | Maximum 100,000 (each) BTU input |
| Opening required for installation: | 27” * Handle adds 2.5”(6.4cm) to depth |



Large capacity 52”x36”x1.5” Deck

Durable Construction

The CW100P is built with *prime 16-gauge cold-rolled top* and 18-gauge sides with a 12-gauge base. The *interior is made of Armco Type 1, 16-gauge aluminized steel*. Also, the CW100P comes standard with a *stainless steel front* made of high quality 18-gauge stainless steel; the door interior is 18 gauge stainless as well.

Energy Efficiency

The CW100P is equipped with our *new energy-saving “Power-Pak” 5-cell burner system* and our unique baffle system. These make the oven highly efficient and helps eliminate hot spots. The *heavily insulated walls*, coupled with our *special vent system*, reduces heat loss yet keep your gas dollars from going up the stack. The CW100P is well-powered by 100,000 BTUs which *increases its efficiency and recovery rate*.

Capacity

The CW100P has a super size *52”x36”x9” deck*. Actual cooking capacity depends on the size of the pizza you are cooking. The CW100P will hold at least twenty 9” pizzas, twelve 12” pizzas, or six 16” pizzas. Cooking time will vary according to product, but will average between 6-8 minutes.

Space Saver

Because the controls are under the door, the CW100P requires *less installation space* than our competition. This enables you to free up valuable kitchen and/or hood space. The actual width needed is a *mere 60” for one super size 52”x36” deck*, almost a foot less than the competition. The CW100P *can convert into a CW200P* by stacking, either initially or after your business grows. This option gives you two 52”x36” decks in only 60” of space.

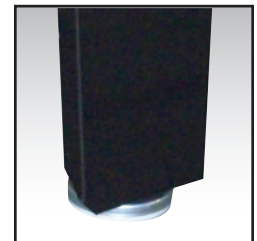

Adjustable Legs

Design Plus

The CW100P has the *controls in lower front for ease of operation and space savings*. This also places the controls in their own *air-conditioned area* so they are not affected by outside influences. In addition, the CW100P is *totally thermocoupled* and allows you to replace individual parts as opposed to throwing away the whole system.



MAXIMIZER

Pizza Ovens

MODEL CW200P

General Features:

- **Quality Construction** for long life
- **Stainless Steel Front Standard**
- **Pizza Decks Standard**
Large 52"x36"x9" compartment
1½" pizza stones
- **Large Capacity**
Forty 9" (22.9cm) pizzas,
Twenty four 12" (30.5cm) pizzas,
or Twelve 16" (43.2cm) pizzas
- **Energy Efficient**
New energy-saving
"Power-Pak" burner system
coupled with our unique baffle
system for even heat and
better baking
- **Full Range Thermostat**
300°F - 650°F (149°C - 343°C)
- **Space Saver**
Only 60" wide
- **Stacked**
Double cooking capacity
- **Easily Serviceable**
All controls can be replaced
from the front of the unit
- **Power**
Gas - LP or NAT
- **Specific features**
of the CW200P listed back

Warranty:

- One year parts



**GAS
FIRED**

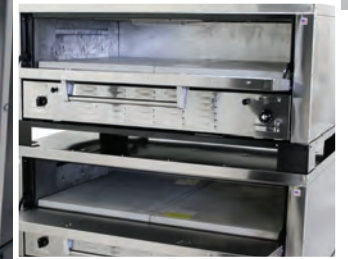

Hearth
Baffle
Burner

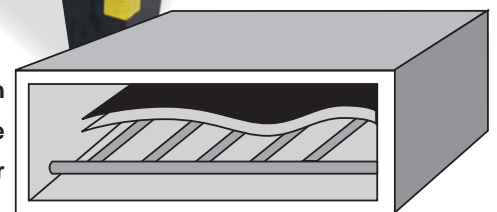

"Power-Pak" 5-Cell Burner System

MORE FOR LESS

More Cooking Space per Floor Space
More Cooking Capacity per Sales Dollar
More Performance per Gas Dollar



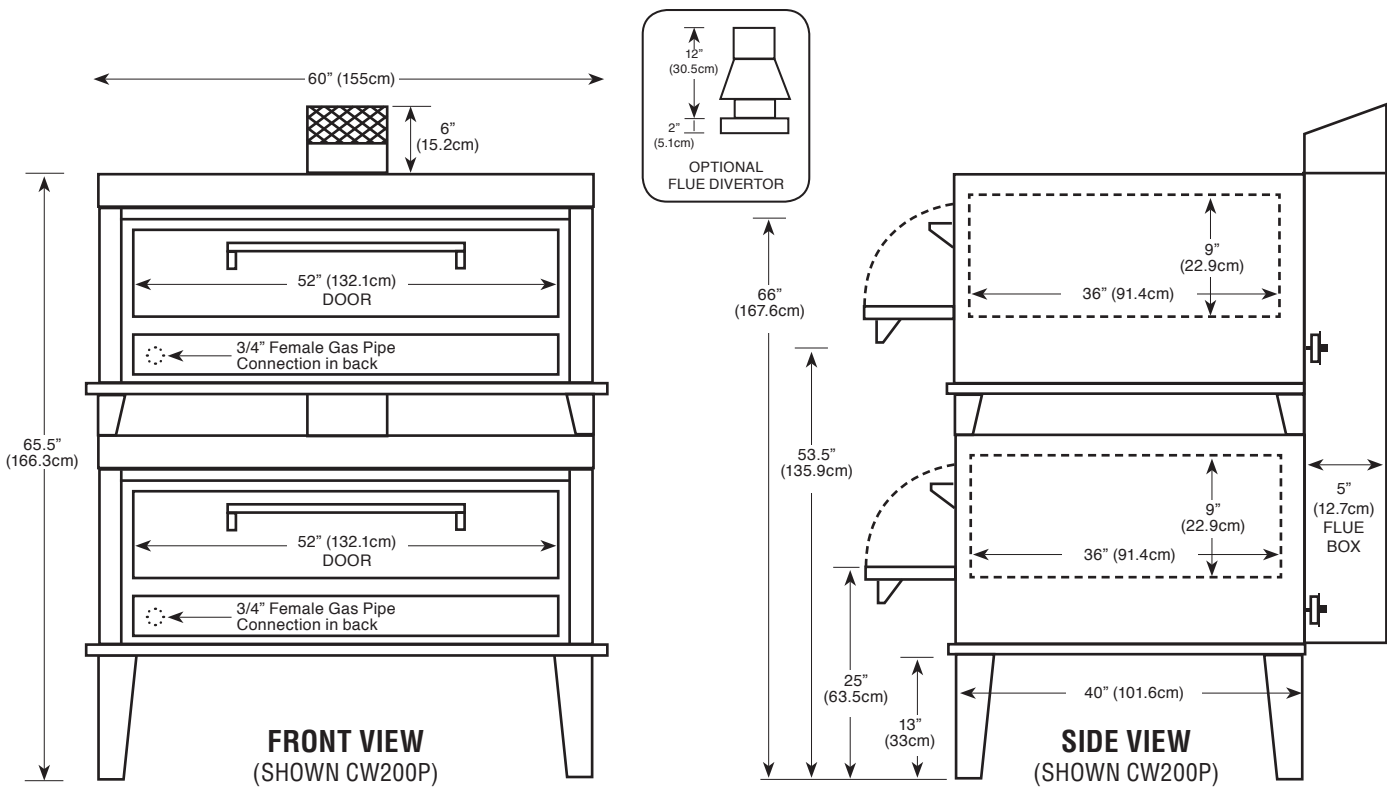

Floor space 60"(155cm) wide x 46"(116.9cm) deep* x 65.5"(166.3cm) high
Shelf size 52"(132.2cm) wide x 36"(91.5.3cm) deep x 9"(22.9cm) high
Shipping weight Two @ 725 lbs (328.8kg)
Capacity Forty 9"(22.9cm), twenty-four 12"(30.5cm) or twelve 16"(43.2cm) pizzas
Gas Maximum 100,000 (each) BTU input
 Opening required for installation: 27" * Handle adds 2.5"(6.4cm) to depth

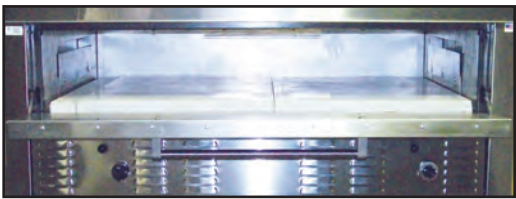

Large capacity 52"x36"x1.5" Deck

Durable Construction

The CW200P is built with *prime 16-gauge cold-rolled top* and 18-gauge sides with a 12-gauge base. The *interior is made of Armco Type 1, 16-gauge aluminized steel*. Also, the CW200P comes standard with a *stainless steel front* made of high quality 18-gauge stainless steel; the door interior is 18 gauge stainless as well.

Energy Efficiency

The CW200P is equipped with our *new energy-saving "Power-Pak" 5-cell burner system* and our unique baffle system. These make the oven highly efficient and helps eliminate hot spots. The *heavily insulated walls*, coupled with our *special vent system*, reduces heat loss yet keep your gas dollars from going up the stack. The CW200P is well-powered by 100,000 BTUs which *increases its efficiency and recovery rate*.

Capacity

The CW200P has a super size *52"x36"x9" deck*. Actual cooking capacity depends on the size of the pizza you are cooking. The CW200P will hold at least forty 9" pizzas, twenty-four 12" pizzas, or twelve 16" pizzas. Cooking time will vary according to product, but will average between 6-8 minutes.

Space Saver

Because the controls are under the door, the CW200P requires *less installation space* than our competition. This enables you to free up valuable kitchen and /or hood space. The actual width needed is a *mere 60" for one super size 52"x36" deck*, almost a foot less than the competition.

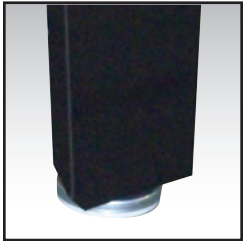

Adjustable Legs

Design Plus

The CW200P has the *controls in lower front for ease of operation and space savings*. This also places the controls in their own *air-conditioned area* so they are not affected by outside influences. In addition, the CW200P is *totally thermocoupled* and allows you to replace individual parts as opposed to throwing away the whole system.



MAXIMIZER

Pizza Ovens

MODEL CW61P

General Features:

- **Quality Construction** for long life
- **Stainless Steel Front Standard**
- **Large Capacity**
2,688 sq. inches of available cooking space. Holds eight (8) 16" pizzas
- **Pizza Decks Standard**
Large 42"x32"x7" compartment
1" pizza stones
- **Unique Interior Design**
Better distribution of heat
- **Energy Efficient**
New energy-saving "Power-Pak" burner system for even heat and better baking (see inset illustration)
- **Full Range Thermostat**
300°F - 650°F (149°C - 343°C)
- **Space Saver**
Only 50" wide
- **Stackable**
Double cooking capacity
- **Easily Serviceable**
All controls can be replaced from the front of the unit
- **Power**
Gas - LP or NAT
- **Specific Features** of the CW61P listed on the back

Warranty:

- One year parts



**GAS
FIRED**



Hearth
Baffle
Burner

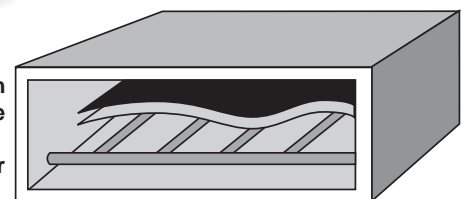

"Power-Pak" 4-Cell Burner System

MORE FOR LESS

More Cooking Space per Floor Space
More Cooking Capacity per Sales Dollar
More Performance per Gas Dollar

Peerless
Commercial and Industrial Ovens

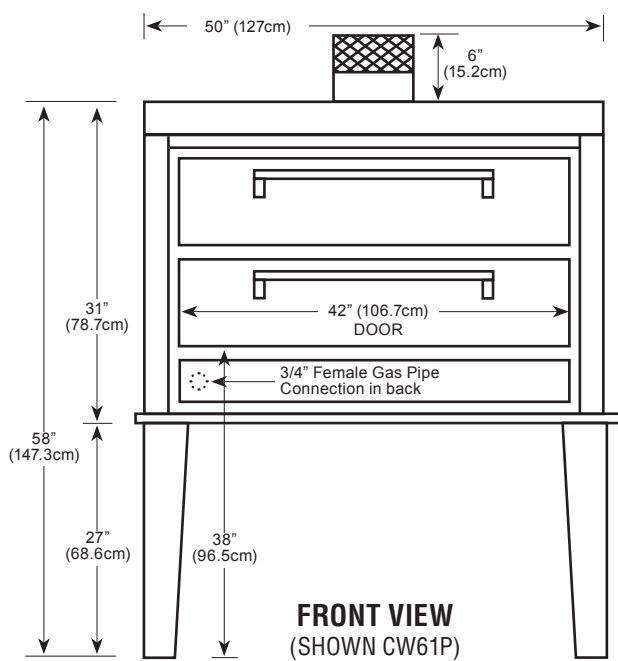
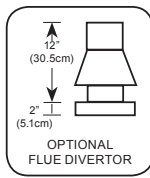

FRONT VIEW
(SHOWN CW61P)

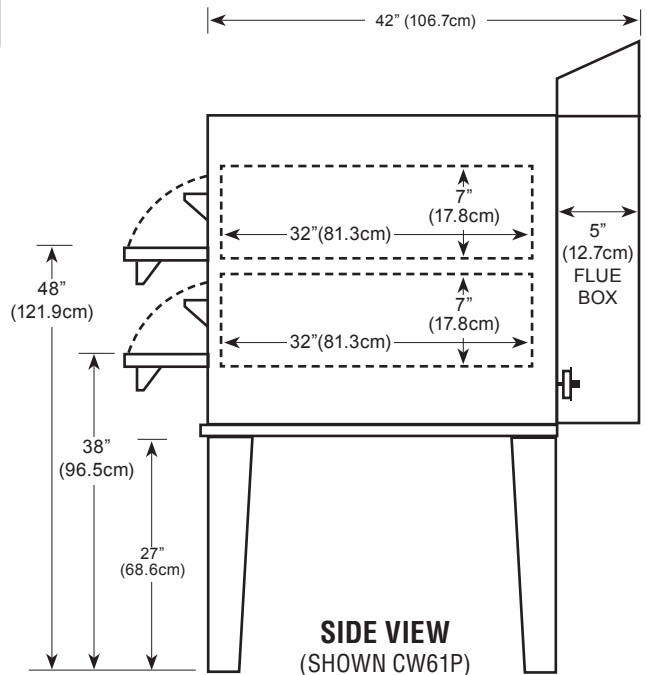

SIDE VIEW
(SHOWN CW61P)

| | |
|------------------------------------|---|
| Floor space | 50" (127cm) wide x 42" (105cm) deep* x 58" (147.3cm) high |
| Shelf size | 42" (106.7cm) wide x 32" (81.3cm) deep x 7" (17.8cm) high |
| Shipping weight | 850 lbs (385.6kg) |
| Capacity for CW61P | Twelve 12" (30.5cm) pizzas or eight 16" (40.7cm) pizzas |
| Gas | 60,000 BTU |
| Opening required for installation: | 32" * Handle adds 2.5" (6.4cm) to depth |

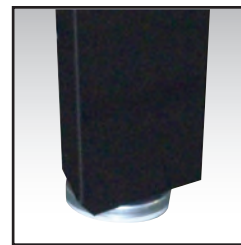

Adjustable Legs

Durable Construction

The CW61P is built with *prime 20-gauge cold-rolled top and sides* with a 14-gauge base. The *interior is made of Armo Type 1, 20-gauge aluminized steel*. The CW61P comes standard with a stainless steel front made of high quality, 18-gauge stainless steel; the door interior is 18 gauge stainless as well.

Energy Efficiency

The CW61P features our *new energy-saving "Power-Pak" 4-cell burner system* and our *unique baffle system*. These make our ovens highly efficient and eliminate hot spots. The *heavily insulated walls*, coupled with our *special vent system*, reduces heat loss and keep your gas dollars from going up the stack. The CW61P is powered by 60,000 highly efficient BTUs which *increase its efficiency and recovery rate*.

Capacity

The CW61P deck size measures 42"x32"x7" (2) decks in one oven. The top deck cooks almost as fast - and as well - as the bottom, providing outstanding capacity for your money. Actual cooking capacity depends on the size of the pizza you are cooking. The CW61P will hold *twelve (12)* 12" pizzas, *eight (8)* 16" pizzas, or *six (6)* 18" pizzas. Cooking time will vary according to product, but will average between 8-10 minutes.

Space Saver

Because the controls are under the doors, the CW61P requires *less installation space* than our competition. This enables you to free up valuable kitchen and/or hood space. The actual width needed is mere 50" for *42"x32"x7" (2) decks*, almost a foot less than the competition. The CW61P *can convert into a CW62PSC by stacking**, either initially or after your business grows. This option gives you four 42"x32" decks in only 56" of space. (*will increase width)

Design Plus

The CW61P has the *controls in the lower front for ease of operation and space savings*. This also places the controls in their own *air-conditioned area* so they are not affected by outside influences. In addition, the CW61P is *totally thermocoupled* and allows you to replace individual parts as opposed to throwing away the whole system.



MAXIMIZER

Pizza Ovens

MODEL CW62PSC

General Features:

- **Quality Construction** for long life
- **Stainless Steel Front Standard**
- **Large Capacity**
5,336 sq. inches of available cooking space. Holds sixteen (16) 16" pizzas
- **Pizza Decks Standard**
Large 42"x32"x7" compartment
1" pizza stones
- **Unique Interior Design**
Better distribution of heat
- **Energy Efficient**
New energy-saving "Power-Pak" burner system for even heat and better baking (see inset illustration)
- **Full Range Thermostat**
300°F - 650°F (149°C - 343°C)
- **Space Saver**
Only 56" wide
- **Easily Serviceable**
All controls can be replaced from the side of the unit
- **Power**
Gas - LP or NAT
- **Specific Features**
of the CW62PSC listed on the back

Warranty:

- One year parts



GAS FIRED

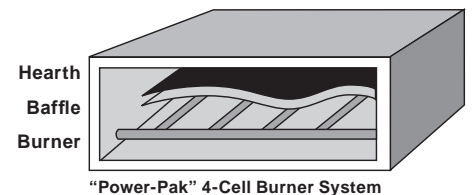

MORE FOR LESS

More Cooking Space per Floor Space
More Cooking Capacity per Sales Dollar
More Performance per Gas Dollar

Peerless
Commercial and Industrial Ovens

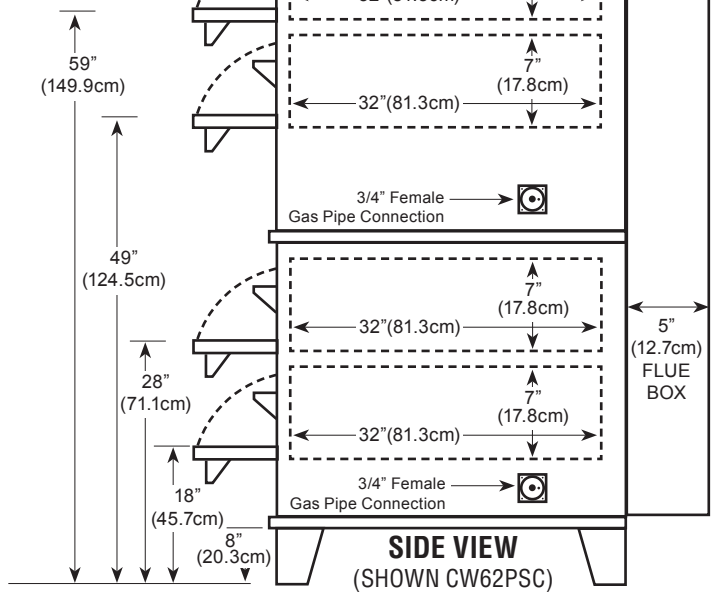
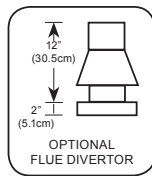
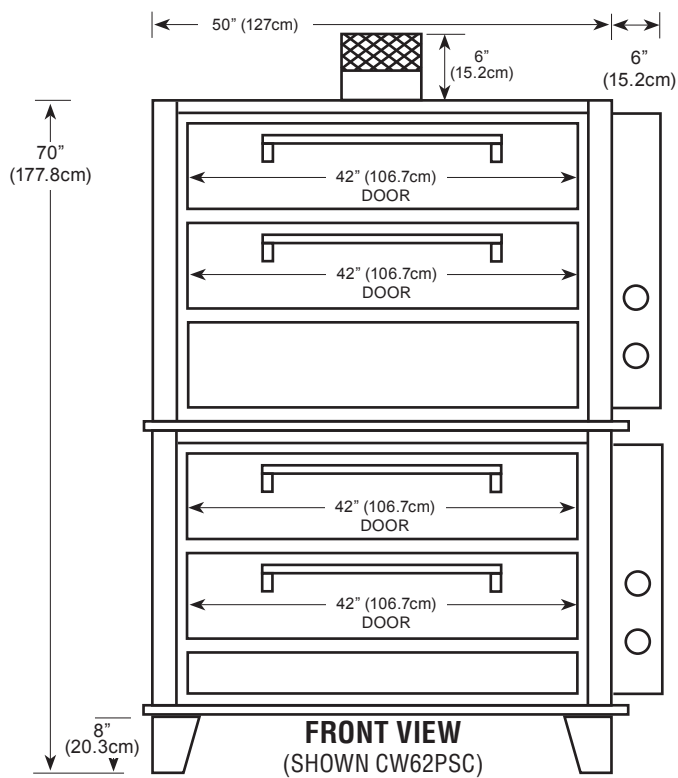

| | |
|------------------------------------|--|
| Floor space | 56" (142.24cm) wide x 42" (105cm) deep* x 70" (177.8cm) high |
| Shelf size | 42" (106.7cm) wide x 32" (81.3cm) deep x 7" (17.8cm) high |
| Shipping weight | 1620 lbs (734kg) |
| Capacity for CW62P | Twenty-four 12" (30.5cm) pizzas or sixteen 16" (40.7cm) pizzas |
| Gas | 120,000 BTU |
| Opening required for installation: | 32" * Handle adds 2.5" (6.4cm) to depth |

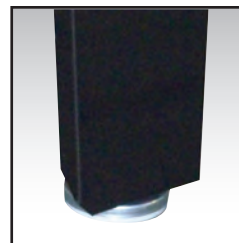

Adjustable Legs



Easy access side controls

Durable Construction

The CW62PSC is built with *prime 20-gauge cold-rolled top and sides* with a 14-gauge base. The *interior is made of Armco Type 1, 20-gauge aluminized steel*. The CW62PSC comes standard with a stainless steel front made of high quality, 18-gauge stainless steel; the door interior is 18 gauge stainless as well.

Energy Efficiency

The CW62PSC features our *new energy-saving "Power-Pak" 4-cell burner system* and our *unique baffle system*. These make our ovens highly efficient and eliminate hot spots. The *heavily insulated walls*, coupled with our *special vent system*, reduces heat loss and keep your gas dollars from going up the stack. The CW62PSC is powered by 120,000 highly efficient BTUs which *increase its efficiency and recovery rate*.

Capacity

The CW62PSC deck size measures 42"x32"x7" (4) decks in two ovens. The top decks cooks almost as fast - and as well as the bottom, providing outstanding capacity for your money. Actual cooking capacity depends on the size of the pizza you are cooking. The CW62PSC will hold *twenty-four (24)* 12" pizzas, *sixteen (16)* 16" pizzas, or *twelve (12)* 18" pizzas. Cooking time will vary according to product, but will average between 8-10 minutes.

Space Saver

The CW62PSC requires *less installation space* than our competition. This enables you to free up valuable kitchen and/or hood space. The actual width needed is mere 56" for 42"x32"x7" (4) decks, almost a foot less than the competition.

Design Plus

The CW62PSC has the *controls on the side for ease of operation and space savings*. This also places the controls in their own *air-conditioned area* so they are not affected by outside influences. In addition, the CW62PSC is *totally thermocoupled* and allows you to replace individual parts as opposed to throwing away the whole system.

2-2-2 Warranty

Two year part warranty, two year labor warranty and a two year trouble free service agreement makes the Peerless line of ovens even more desirable.



MAXIMIZER

Pizza Ovens

MODEL CE61PE

General Features:

- **Quality Construction** for long life
- **Stainless Steel Front Standard**
- **Large Capacity**
2,688 sq. inches of available cooking space. Holds (8) eight 16" pizzas
- **Pizza Decks Standard**
Large 42"x32"x7" compartment
1" pizza stones
- **Unique Interior Design**
Better distribution of heat
- **Energy Efficient**
Energy-saving tubular elements coupled with our unique baffle system for even heat and better baking
- **Full Range Digital Thermostat**
300°F - 650°F (149°C - 343°C)
Precise temperature control
- **Solid State Relay**
Silent operation
- **Space Saver**
Only 50" wide
- **Easily Serviceable**
All controls can be replaced from the front of the unit
- **Power**
Electric
Single phase standard
Three phase optional
- **Top Heat Control** 
Balances oven heat
- **Specific Features** of the CE61PE listed on the back

Warranty:

- One year parts and labor



ELECTRIC



MORE FOR LESS

- More Cooking Space per Floor Space
- More Cooking Capacity per Sales Dollar
- More Performance per Dollar

Peerless
Commercial and Industrial Ovens

For international sales: sales@edainternational.com / sales@mbhny.com

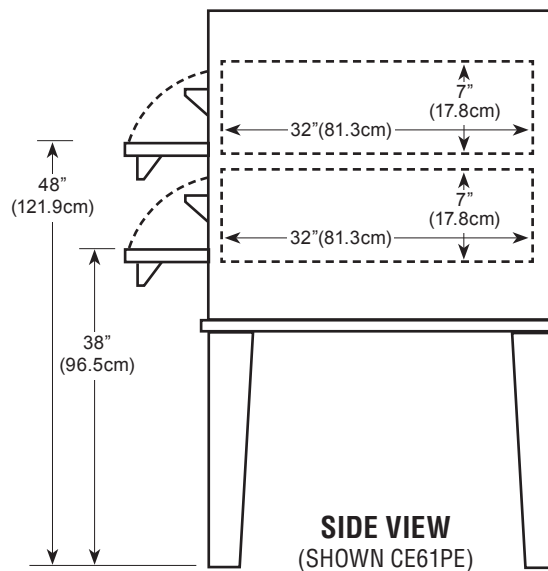
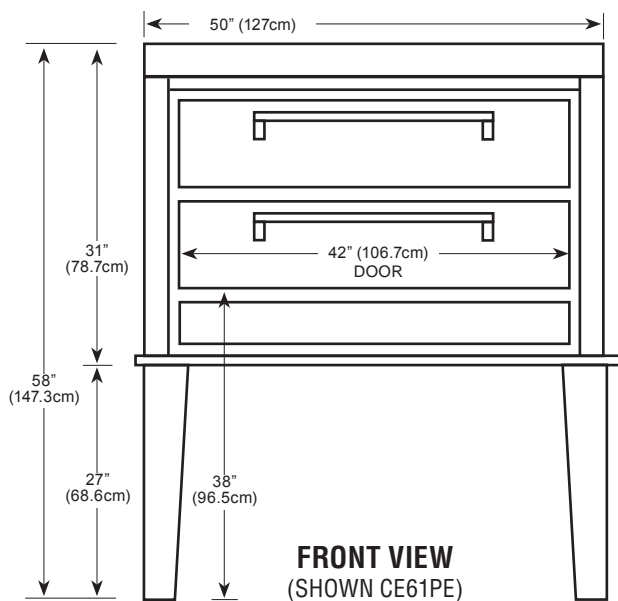

| | |
|------------------------------------|--|
| Floor space | 50"(127cm) wide x 42"(105cm) deep* x 58"(147.3cm) high |
| Shelf size | 42"(106.7cm) wide x 32"(81.3cm) deep x 7"(17.8cm) high |
| Shipping weight | 850 lbs (385.6kg) |
| Capacity for CE61PE | Twelve 12" (30.5cm) pizzas or eight 16" (40.7cm) pizzas |
| Electric | 12KW - 220V single phase, 60 AMPS Optional three phase, 40 AMPS |
| Opening required for installation: | 32" * Handle adds 2.5"(6.4cm) to depth |

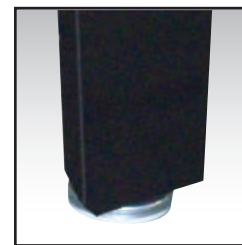

Digital Electronic Controller

Adjustable Legs

Durable Construction

The CE61PE is built with *prime 20-gauge cold-rolled top and sides* with a 14-gauge base. The *interior is made of Armco Type 1, 20-gauge aluminized steel*. The CE61PE comes standard with a stainless steel front made of high quality, 18-gauge stainless steel; the door interior is 18 gauge stainless as well.

Energy Efficiency

The CE61PE is equipped with six (6) energy saving tubular elements and with our unique baffle system, makes the oven highly efficient and eliminates hot spots. The heavily insulated walls coupled with a no vent system, reduces heat loss and keeps the area safe for workers. The CE61PE is well powered by 12,000 watts, which enables it to have an extremely fast recovery rate.

Capacity

The CE61PE deck size measures 42"x32"x7" (2) decks in one oven. The top deck cooks almost as fast - and as well - as the bottom, providing outstanding capacity for your money. Actual cooking capacity depends on the size of the pizza you are cooking. The CE61PE will hold **twelve (12)** 12" pizzas, **eight (8)** 16" pizzas, or **six (6)** 18" pizzas. Cooking time will vary according to product, but will average between 8-10 minutes.

Space Saver

Because the controls are under the doors, the CE61PE requires *less installation space* than our competition. This enables you to free up valuable kitchen and/or hood space. The actual width needed is mere 50" for 42"x32"x7" (2) decks, almost a foot less than the competition. The CE61PE *can convert into a CE62PESC by stacking**, either initially or after your business grows. This option gives you four (4) 42"x32" decks in only 56" of space. (*will increase width)

Design Plus

The CE61PE has digital *controls in lower front for ease of operation and space savings*. This also places the controls in their own *air-conditioned area* so they are not affected by outside influences. In addition, the CE61PE has a new feature: *adjustable top heat control to balance heat between upper and lower decks*.



MAXIMIZER

Pizza Ovens

MODEL CE62PESC

General Features:

- **Quality Construction** for long life
- **Stainless Steel Front Standard**
- **Large Capacity**
5,376 sq. inches of available cooking space. Holds sixteen (16) 16" pizzas
- **Pizza Decks Standard**
Large 42"x32"x7" compartment
1" pizza stones
- **Unique Interior Design**
Better distribution of heat
- **Energy Efficient**
Energy-saving tubular elements coupled with our unique baffle system for even heat and better baking
- **Full Range Digital Thermostat**
300°F - 650°F (149°C - 343°C)
Precise temperature control
- **Solid State Relay**
Silent operation
- **Space Saver**
Only 56" wide
- **Easily Serviceable**
All controls can be replaced from the side of the unit
- **Power**
Electric
Single phase standard
Three phase optional
- **Top Heat Control**
Balances oven heat

Warranty:

- One year parts



ELECTRIC



MORE FOR LESS

More Cooking Space per Floor Space
More Cooking Capacity per Sales Dollar
More Performance per Dollar



For international sales: sales@edainternational.com / sales@mbhny.com

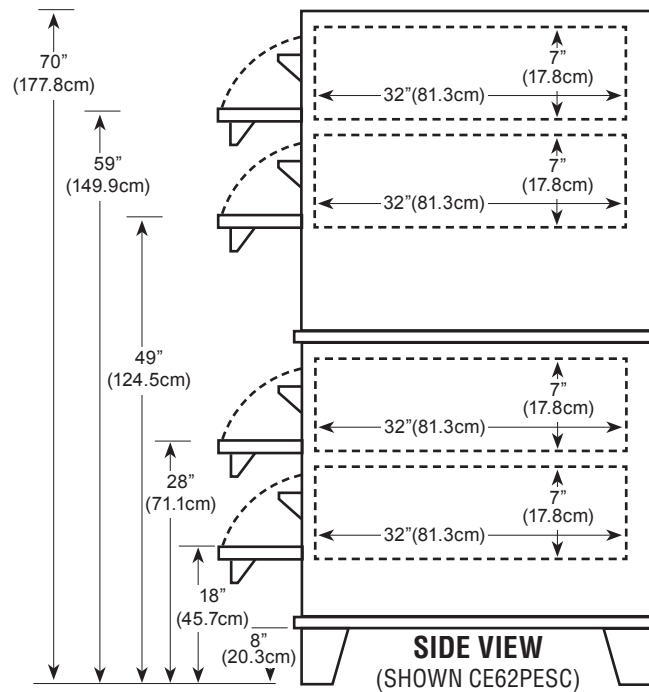
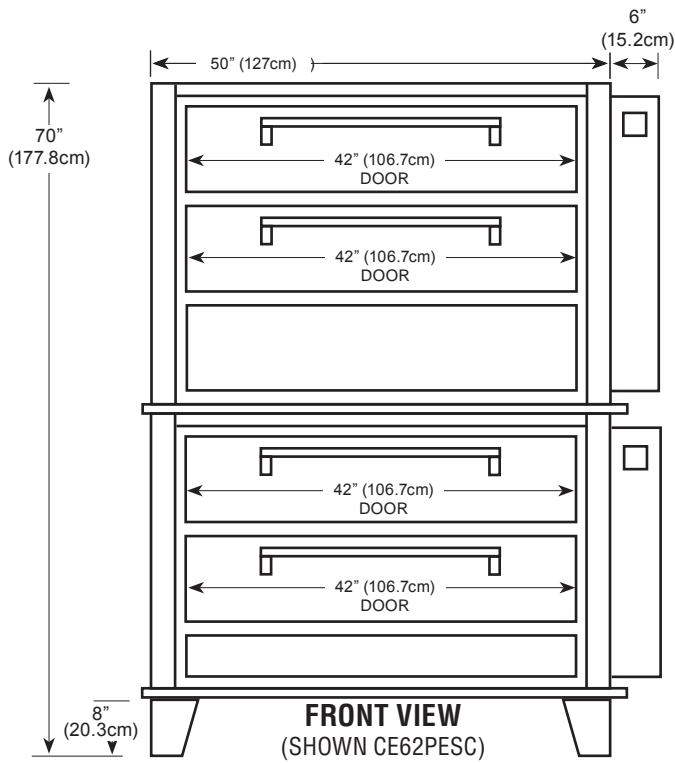

| | |
|--|---|
| Floor space | 56" (142.24cm) wide x 42" (105cm) deep* x 70" (177.8cm) high |
| Shelf size | 42" (106.7cm) wide x 32" (81.3cm) deep x 7" (17.8cm) high |
| Shipping weight | 1680 lbs (762kg) |
| Capacity for CE62PESC | Twenty-four 12" (30.5cm) pizzas or sixteen 16" (40.7cm) pizzas |
| Electric | 24KW - 220V single phase, 120 AMPS Optional three phase, 80 AMPS |
| Two electrical connections for this model | |
| Opening required for installation: 32" * Handle adds 2.5" (6.4cm) to depth | |

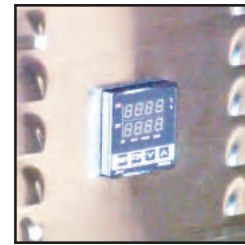

Digital Electronic Controller

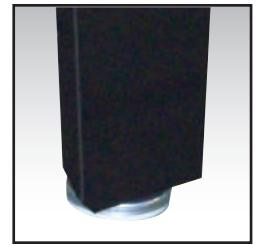

Adjustable Legs

Durable Construction

The CE62PESC is built with *prime 20-gauge cold-rolled top and sides* with a 14-gauge base. The *interior is made of Armco Type 1, 20-gauge aluminized steel*. The CE62PESC comes standard with a stainless steel front made of high quality, 18-gauge stainless steel; the door interior is 18 gauge stainless as well.

Energy Efficiency

The CE62PESC is equipped with twelve (12) energy saving tubular elements and with our unique baffle system, makes the oven highly efficient and eliminates hot spots. The heavily insulated walls coupled with a no vent system, reduces heat loss and keeps the area safe for workers. The CE62PESC is well powered by 24,000 (2) watts, which enables it to have an extremely fast recovery rate.

Capacity

The CE62PESC deck size measures 42"x32"x7" (4) decks in two ovens. The top deck cooks almost as fast - and as well as the bottom, providing outstanding capacity for your money. Actual cooking capacity depends on the size of the pizza you are cooking. The CE62PESC will hold **twenty-four (24)** 12" pizzas, **sixteen (16)** 16" pizzas, or **twelve (12)** 18" pizzas. Cooking time will vary according to product, but will average between 8-10 minutes.

Space Saver

The CE62PESC requires *less installation space* than our competition. This enables you to free up valuable kitchen and/or hood space. The actual width needed is mere 56" for 42"x32"x7" (4) decks, almost a foot less than the competition.

Design Plus

The CE62PESC has digital *controls on the side for ease of operation and space savings*. This also places the controls in their own *air-conditioned area* so they are not affected by outside influences. In addition, the CE62PESC has a new feature: *adjustable top heat control to balance heat*.

2-2-2 Warranty

Two year part warranty, two year labor warranty and a two year trouble free service agreement makes the Peerless line of ovens even more desirable.



MAXIMIZER

Multideck Pizza Ovens

MODEL 2324P

General Features:

- **Quality Construction** for long life
- **Stainless Steel Front Standard**
All stainless steel available
- **Time Proven**
Over 100 years of design life
- **Large Capacity**
2904 sq. inches of available cooking space.
Holds eight (8) 16" pizzas
- **Pizza Decks Standard**
Large 33"x22"x7" compartment
1" pizza stones
- **Energy Efficient**
New energy-saving burner system (60,000 BTU)
- **Aluminized Interior**
- **Pizza Thermostat Standard**
300° F-650° F (149°C-343°C)
- **Versatile**
Perfect for a variety of baking needs
- **Easily Serviceable**
All controls can be replaced from the front of the unit
- **Power**
Gas - LP or NAT
- **Specific Features** of the 2324P listed on the back

Warranty:

- One year parts



GAS ONLY

MORE FOR LESS

More Cooking Space per Floor Space
More Cooking Capacity per Sales Dollar
More Performance per Gas Dollar



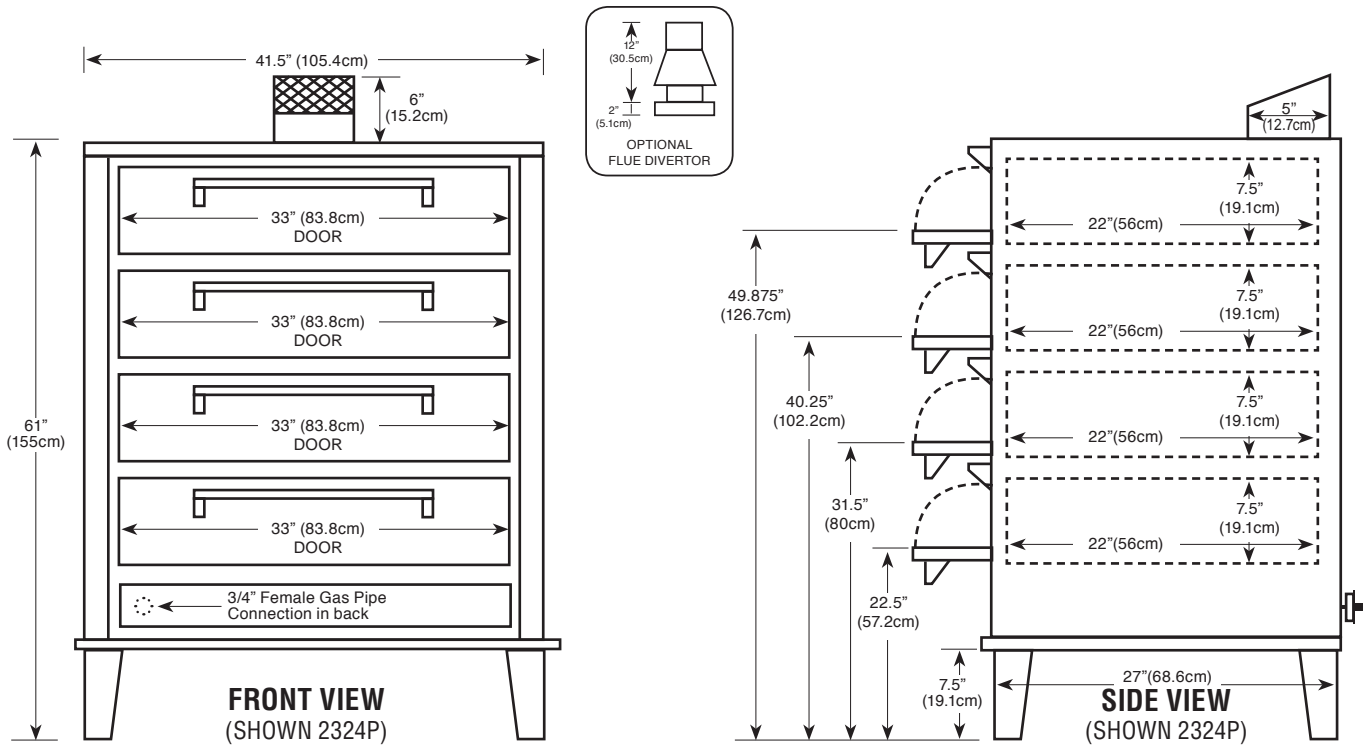

| MODEL # | DECK | | | BODY | | | MAX BTU INPUT | SHIPPING WEIGHT | CAPACITY INTERIOR |
|---------|---------------|-------------|----------------|------------------|---------------|--------------|---------------|------------------|---------------------|
| | W | D | H | W | D | H | | | |
| 2324P | 33" 83.8cm | 22" 56cm | 7.5" 19.1cm | 41.5" 105.4cm | 27" 68.6cm | 61" 155cm | 60,000 | 750 lbs 340kg | EIGHT 16" PIZZAS |

Opening required for installation: 27" *

*Handles and doors can be removed to reduce depth for tight entries

Durable Construction

The "2300 series" ovens are constructed on a 14-gauge, hot-rolled base with prime 20-gauge, cold-rolled top and sides. The interior is made of *Armco Type-1, 20-gauge, aluminized steel*. The steel shelves are made of 16-gauge, aluminized steel.

Energy Efficiency

The Peerless multideck ovens are equipped with highly *efficient steel tubular burners*. The 2324P, four-pan oven has four (4), tubular burners that supply 60,000 BTU's for great performance and fast recovery. All units are equipped with *modern safety pilots and thermostats*. Comes with a separate on/off valve.

Space Savers

Because our unique construction and the fact the controls are under the door, the Peerless multideck ovens are by far the most space conscious ovens on the market today. The 2324P, four-pan oven requires only 41.5" while the eight-pan requires only 51.5". This frees up valuable kitchen and/or hood space.

Capacity

Each of the four (4) decks of the 2324P, four-pan oven measure 33"x22"x7.5". They can easily handle one (1) 18"x26" pan, two (2) 12" pizzas or a two (2) 16" pizzas, using only 41.5" of space. Total of four (4) 18"x26" pans, eight (8) 12" pizzas or eight (8) 16" pizzas.



Adjustable Legs

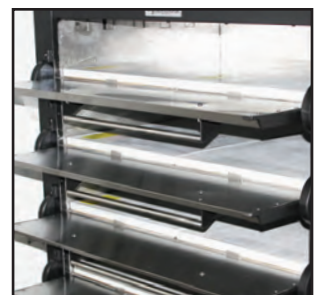

Adjustable Dampers at each deck



Easy access front controls



Commercial and Industrial Ovens

For international sales: sales@edainternational.com / sales@mbhny.com

MAXIMIZER

Multideck Pizza Ovens

MODEL 2348P

General Features:

- **Quality Construction** for long life
- **Stainless Steel Front Standard**
All stainless steel available
- **Time Proven**
Over 100 years of design life
- **Large Capacity**
5376 sq. inches of available cooking space.
Holds sixteen (16) 16" pizzas
- **Pizza Decks Standard**
Large 42"x32"x7" compartment
1" pizza stones
- **Energy Efficient**
New energy-saving burner system (96,000 BTU)
- **Aluminized Interior**
- **Pizza Thermostat Standard**
300° F-650° F (149°C-343°C)
- **Versatile**
Perfect for a variety of baking needs
- **Easily Serviceable**
All controls can be replaced from the front of the unit
- **Power**
Gas - LP or NAT
- **Specific Features** of the 2348P listed on the back

Warranty:

- One year parts



GAS ONLY

MORE FOR LESS

More Cooking Space per Floor Space
More Cooking Capacity per Sales Dollar
More Performance per Gas Dollar



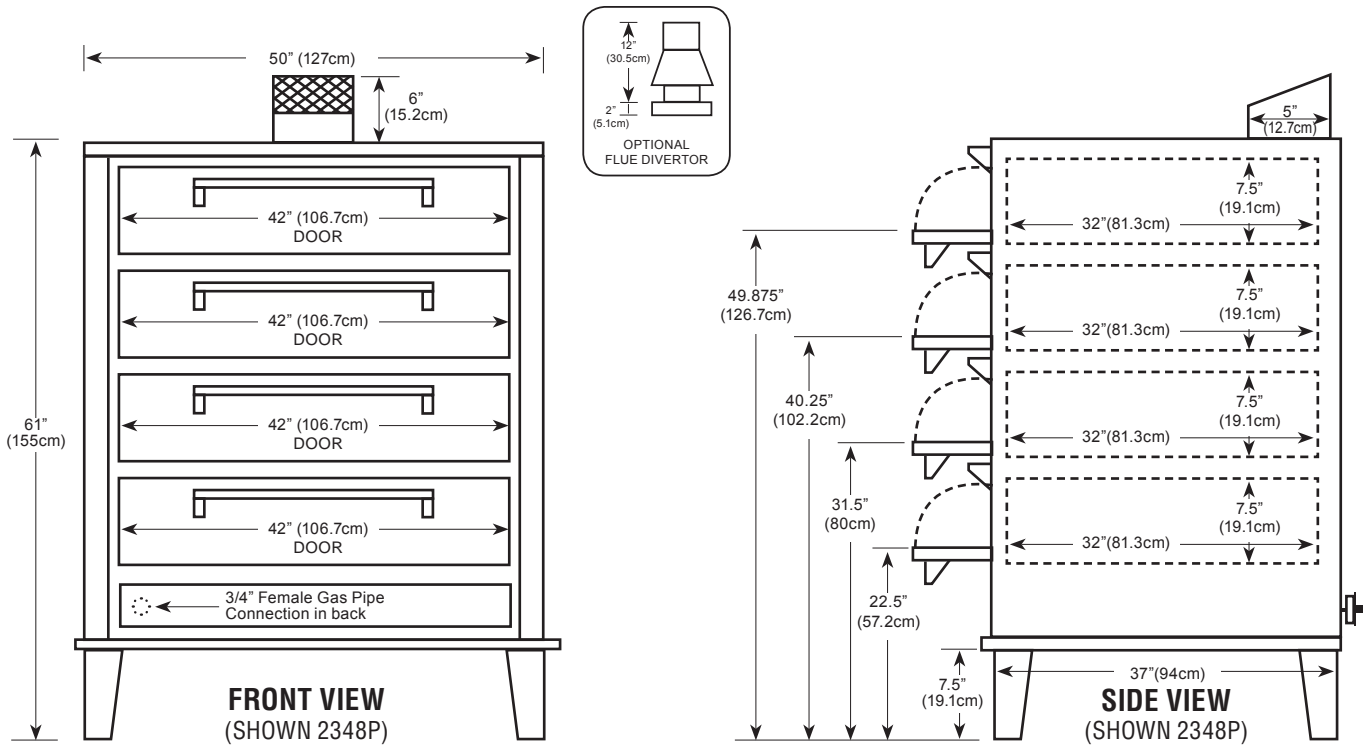

| MODEL # | DECK | | | BODY | | | MAX BTU INPUT | SHIPPING WEIGHT | CAPACITY INTERIOR |
|---------|----------------|---------------|----------------|--------------|-------------|--------------|---------------|-------------------|-----------------------|
| | W | D | H | W | D | H | | | |
| 2348P | 42" 106.7cm | 32" 81.3cm | 7.5" 19.1cm | 50" 127cm | 37" 94cm | 61" 155cm | 96,000 | 1200 lbs 544kg | SIXTEEN 16" PIZZAS |

Opening required for installation: 37" *

*Handles and doors can be removed to reduce depth for tight entries

Durable Construction

The "2300 series" ovens are constructed on a 14-gauge, hot-rolled base with prime 20-gauge, cold-rolled top and sides. The interior is made of *Armco Type-1, 20-gauge, aluminized steel*. The steel shelves are made of 16-gauge, aluminized steel.

Energy Efficiency

The Peerless multideck ovens are equipped with highly *efficient steel tubular burners*. The 2348P, eight-pan oven is equipped with six (6), tubular burners that supply 96,000 BTU's. All units are equipped with *modern safety pilots and thermostats*. Comes with separate on/off valve.

Space Savers

Because our unique construction and the fact the controls are under the door, the Peerless multideck ovens are by far the most space conscious ovens on the market today. The 2348P, four-pan oven requires only 50". This frees up valuable kitchen and/or hood space.

Capacity

Each of the four (4) decks of the 2348P, eight-pan oven measures 42"x32"x7.5" capable of holding two (2) 18"x26" bun pans, six (6) 12" pizzas, or four (4) 16" pizzas each, and using only 50" of space. Total of eight (8) 18"x26" pans, twenty-four (24) 12" pizzas or sixteen (16) 16" pizzas.



Adjustable Legs

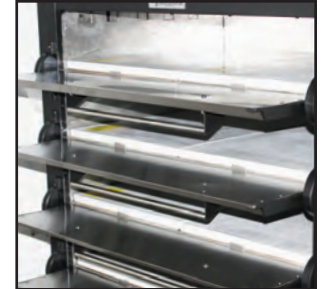

Adjustable Dampers at each deck



Easy access front controls



For international sales: sales@edainternational.com / sales@mbhny.com

MAXIMIZER

Pizza Ovens

MODEL C131P

General Features:

- **Quality Construction** for long life
- **Stainless Steel Front** Standard
- **Large Capacity**
1,824 sq. inches of available cooking space on four, cordierite decks
- **Pizza Decks Standard**
Large 24"x19"x15" compartment
1/2" pizza stones
- **Unique Interior Design**
Better distribution of heat
- **Energy Efficient**
New energy-saving "Power-Pak" burner system coupled with our unique baffle system for even heat and better baking
- **Full Range Thermostat**
300°F - 650°F (149°C - 343°C)
- **Versatile**
Removable trays increase oven capabilities
- **Easily Serviceable**
All controls can be replaced from the front of the unit
- **Power**
Gas - LP or NAT
- **Specific Features** of the C131P listed on the back

Warranty:

- One year parts



**GAS
FIRED**



MORE FOR LESS

More Cooking Space per Floor Space
More Cooking Capacity per Sales Dollar
More Performance per Gas Dollar



Commercial and Industrial Ovens

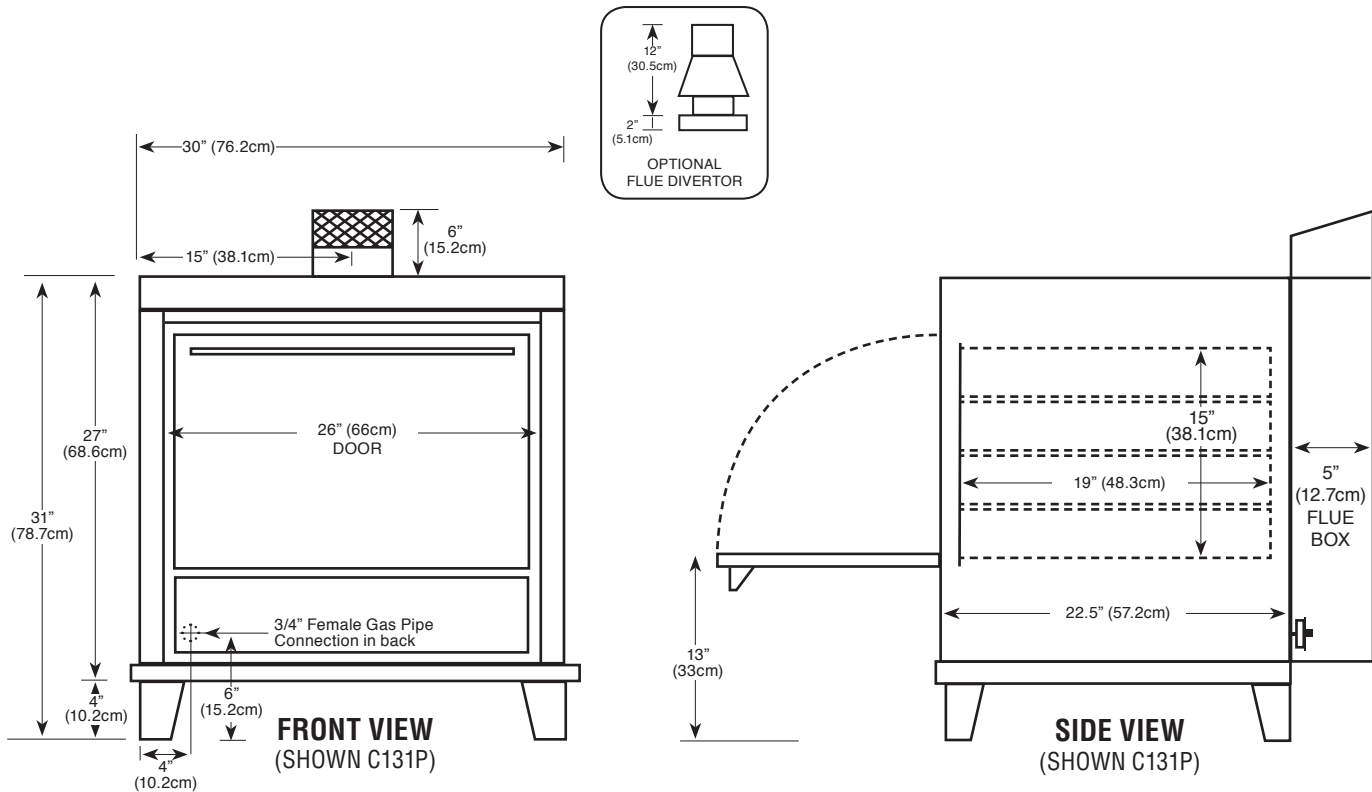

| | |
|--|--|
| Counter space | 30" (76.2cm) wide x 22.5" (57.2cm) deep* x 31" (78.7cm) high |
| Shelf size | 24" (61cm) wide x 19" (48.3cm) deep |
| Shipping weight | 350 lbs (158.8kg) |
| Capacity | Eight 9" (22.9cm) pizzas or four 18" (45.7cm) pizzas |
| Shelves | Four (4) |
| Gas | 30,000 BTUs |
| Opening required for installation: 30" * Handle adds 2.5" (6.4cm) to depth | |

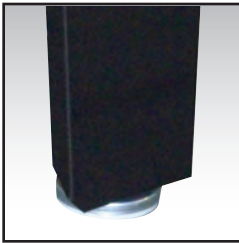

Adjustable Legs

Durable Construction

The C131P is built with *prime 20-gauge cold-rolled sides* and topped with a 16-gauge base. The *interior is made of Armco Type 1, 20-gauge aluminized steel*. Also, the C131P comes standard with a stainless steel front using high quality 18-gauge stainless steel.

Energy Efficiency

The C131P is equipped with our *new energy-saving "Power-Pak" 3-cell burner system* and our unique baffle system which make the oven highly efficient and helps eliminate hot spots. The *heavily insulated walls* coupled with our *special vent system* reduce heat loss yet keep the area safe for workers. The C131P is well-powered by 30,000 BTUs which enables it to have an *extremely fast recovery rate*.

Versatility

The C131P comes with *removable shelves* which increase the oven's capabilities for either *baking or roasting* (this feature comes with the gas oven only). This counter top unit is also *double stackable* for double the capacity, double the efficiency and double the profits. The C131P comes with an *optional floor base* (SPK31) for extra storage.

Capacity C131P

The C131P is the only *single-door, four shelf* pizza oven available. It houses *four cordierite decks* which offers 456 square inches (2941.9 sq cm) of cooking area per shelf. That equals *1,824 total square inches (11,767.7 sq cm) per oven*.



SPK31 STAND

- Sideliners hold racks or stones
- Optional casters (shown)
- Optional racks (3) (shown)
- 30" (76.2cm) x 22.625" (57.5cm) x 26.25" (66.5cm)

When double stacked, the C231P offers eight shelves, which brings your total cooking area to 3,648 square inches (23,535.4 sq cm). When you compare the cost per shelf or per square inch to other two- or three- shelf ovens, Peerless is by far the greatest value.

Design Plus C131P

The C131P has the controller in the lower front for ease of operation, to save space and in their very own air conditioned area so they are not affected by outside influences. The C131P is totally thermocoupled and allows you to replace individual parts without replacing the entire system.

